

6 M19.3

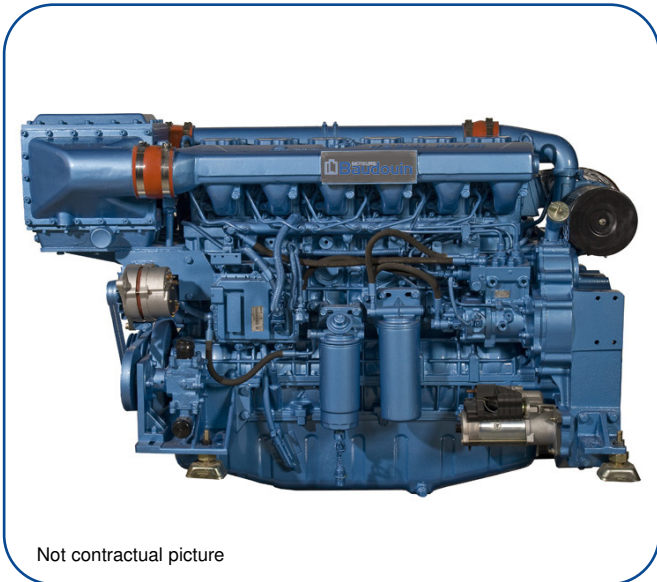

Not contractual picture

4 stroke diesel engine, direct injection, common-rail

Bore and stroke	126 x 155 mm
Number of cylinders	6 in line
Total displacement	11.6 litres
Compression ratio	17/1
Engine rotation (ISO 1204 standard)	CCW *
Idle speed	600 rpm
Weight (without water & oil)	1200 kg
Flywheel housing	SAE 1
Flywheel	SAE 14"

* counter-clockwise

RATED POWER

Duty	rpm	kW	hp	Full load fuel consumption (g / kW.h)	IMO
P1	1800	331	450	199	II
P2	2100	368	500	205	II
P3	2100	404	550	209	II
P4	2200	425	578	218	II

STANDARD EQUIPMENTS

Engine and block

- Cast iron cylinder block, with replaceable cylinder liners
- Separate cast iron cylinder heads equipped with 4 valves
- Replaceable valves guides and seats
- Steel forged crankshaft with 7 bearings
- Lube oil cooled light alloy piston with 3 high performance piston rings

Cooling system

- Fresh / raw water heat exchanger with integrated thermostatic valves and expansion tank
- Cast iron centrifugal fresh water pump, mechanically driven
- Bronze self-priming raw water pump, mechanically driven

Lubrication system

- Full flow duplex type oil filters
- Fresh water cooled lube oil cooler plate type

Fuel system

- Electronic common-rail injection
- Double wall injection bundle with alarm and leakage collector
- Duplex fuel filters replaceable engine running
- Water separator

Intake air and exhaust system

- Exhaust gas manifold cooled by the engine fresh water
- Dry turbo blower insulated
- Low water temperature cooled intake air cooler

Electrical system

- Voltage: 24Vcc
- Electrical starter on flywheel crown
- 35A battery charger
- Wheelhouse control panel

OPTIONAL EQUIPMENTS (extracts) *

- Cooling system adapted for box / keel cooling
- Connection for emergency raw water circuit
- Bilge pump
- Air starter
- Promachined free end PTO

- Resilient mounts under engine
- Exhaust water injection after turbocharger
- Fresh water electrically heated
- Cabin heating

* contact us for further information regarding our options.

	P1 duty	P2 duty	P3 duty	P4 duty
Application	unrestricted continuous	continuous	intermittent	high performance
Engine load variations	very little or none	continuous	important	very important
Mean engine load factor	80 to 100 %	30 to 80 %	50 %	30 %
Annual working time	more than 5000 h	3000 to 5000 h	1000 to 3000 h	less than 1000 h
Time at full load	unlimited	8 h each 12 h	2 h each 12 h	1 h each 12 h

DIMENSIONS

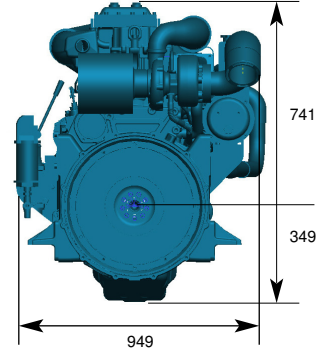
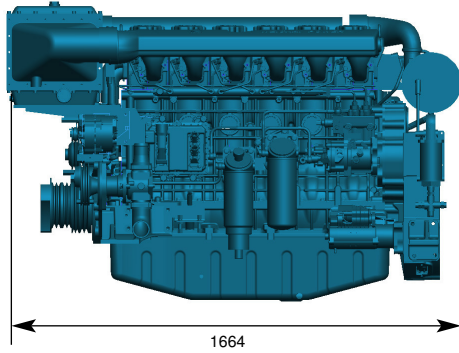

Power definition

Standard ISO 3046/1 - 1995 (F)

Reference conditions

Ambiant temperature 25 °C / 77 °F
 Barometric pressure 100 kPa
 Relative humidity 30 %
 Raw water temperature 25 °C / 77 °F

Limit conditions ISO 3046

Fuel oil

Relative density 0,840 ± 0,005
 Lower calorific power 42 700 kJ/kg
 Consumption tolerances 0 ± 5 %
 Inlet limit temperature 35 °C / 95 °F

Our ratings also comply with classification societies maximum temperature definition without power derating.

Ambiante temperature 45 °C / 113 °F
 Raw water temperature 32 °C / 90 °F

P1 rating - 331 kW / 450 hp @ 1800 rpm

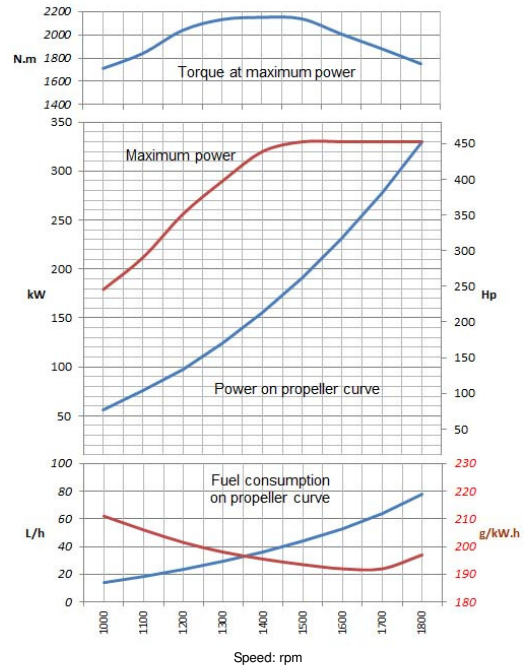

P2 rating - 368 kW / 500 hp @ 2100 rpm

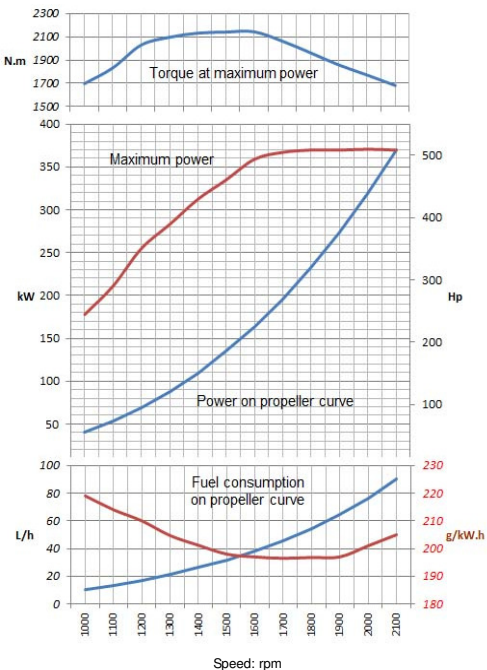

P3 rating - 404 kW / 550 hp @ 2100 rpm

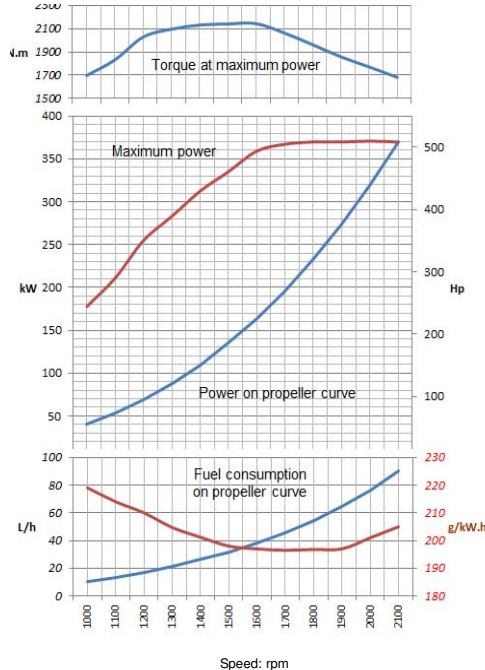

P4 rating - 425 kW / 578 hp @ 2200 rpm

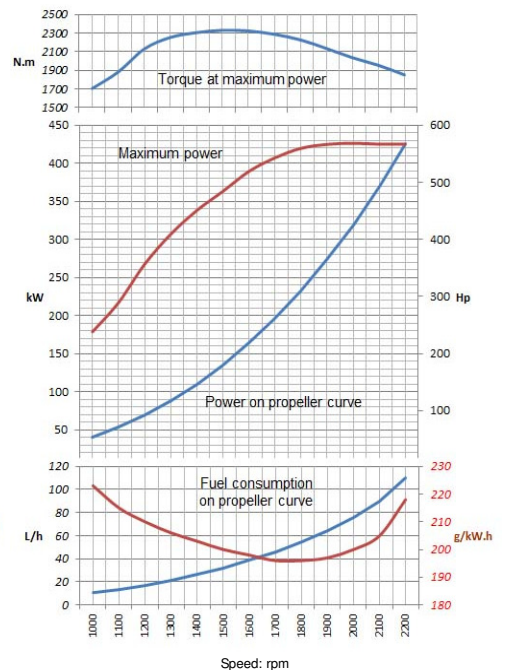

Moteurs Baudouin reserve the right to modify these specifications, without notice. Document not contractual.